



Terex® Minerals Processing Systems

JW SERIES JAW CRUSHERS



WORKS FOR YOU.™

DESIGNED TO DELIVER

Terex® JW Series

We have been manufacturing jaw crushers for over 120 years and have gained a well-known reputation for producing heavy-duty machines to match the most arduous crushing conditions encountered.

All of this experience has been used in the design of our JW Series of single toggle jaw crushers, built for trouble-free operation in heavy and continuous applications. Designed to suit track, mobile or static plant installations these rugged machines are manufactured with heavy-duty components for optimum operation and long life.

Typical applications for our single toggle jaw crushers are in mining, quarrying and recycling. The jaw crushers handle ores, rock, gravel and recycled concrete.

Each machine is backed by the Terex® Minerals Processing Systems total after-market service and spare parts.



Benefits and Features

▶ **Long life, low maintenance and reduced operating cost**

Robust frame design and large diameter, forged main shaft with no threads or sharp radii that can cause stress concentrations.

▶ **Simple installation**

Adaptable mounting arrangement suitable for static or mobile installation.

▶ **Easy adjustment**

Hydraulic closed side setting adjustment through a hydraulic wedge arrangement fully enclosed within the crusher frame.

▶ **Simple maintenance**

Jaw-faces are retained by a mechanical wedge locking system removing the need to access bolts behind the cast front end frame of the crusher. Replaceable backing plates protect the jaw die seating areas on the front end frame and swing jaw holder.

▶ **Even distribution of crushing forces across the jaw locations**

Machined jaw-face locations.

▶ **Bearings kept free from dust and water**

Grease-purged labyrinth dust seals.

▶ **Reliable operation with minimal downtime**

Precision machined cast jaw-holder, "rolling-end" non-lubricated toggle and self aligning spherical roller bearings combine with a high strength shaft and mainframe to provide extreme reliability which has become well known in the industry.

▶ **Smooth running operation**

Balanced fly wheel and drive pulley.



WORKS FOR YOU.™

BUILT TOUGH

JW Series Jaw Crusher Construction

1. Protector plate
2. Moving jaw retention wedge
3. Abrasion resistant side liners (illustration represents liner design of JW40 only)
4. Fixed jaw retention wedge
5. Replaceable backing plate
6. Rolling end toggle
7. Closed side setting wedge adjustment
8. Hydraulic tension spring
9. Extended jaw-face liners for discharge protection
10. Bolted support feet can be arranged for fixed or mobile applications (JW42 has replaceable bolt-on toe on swingstock)

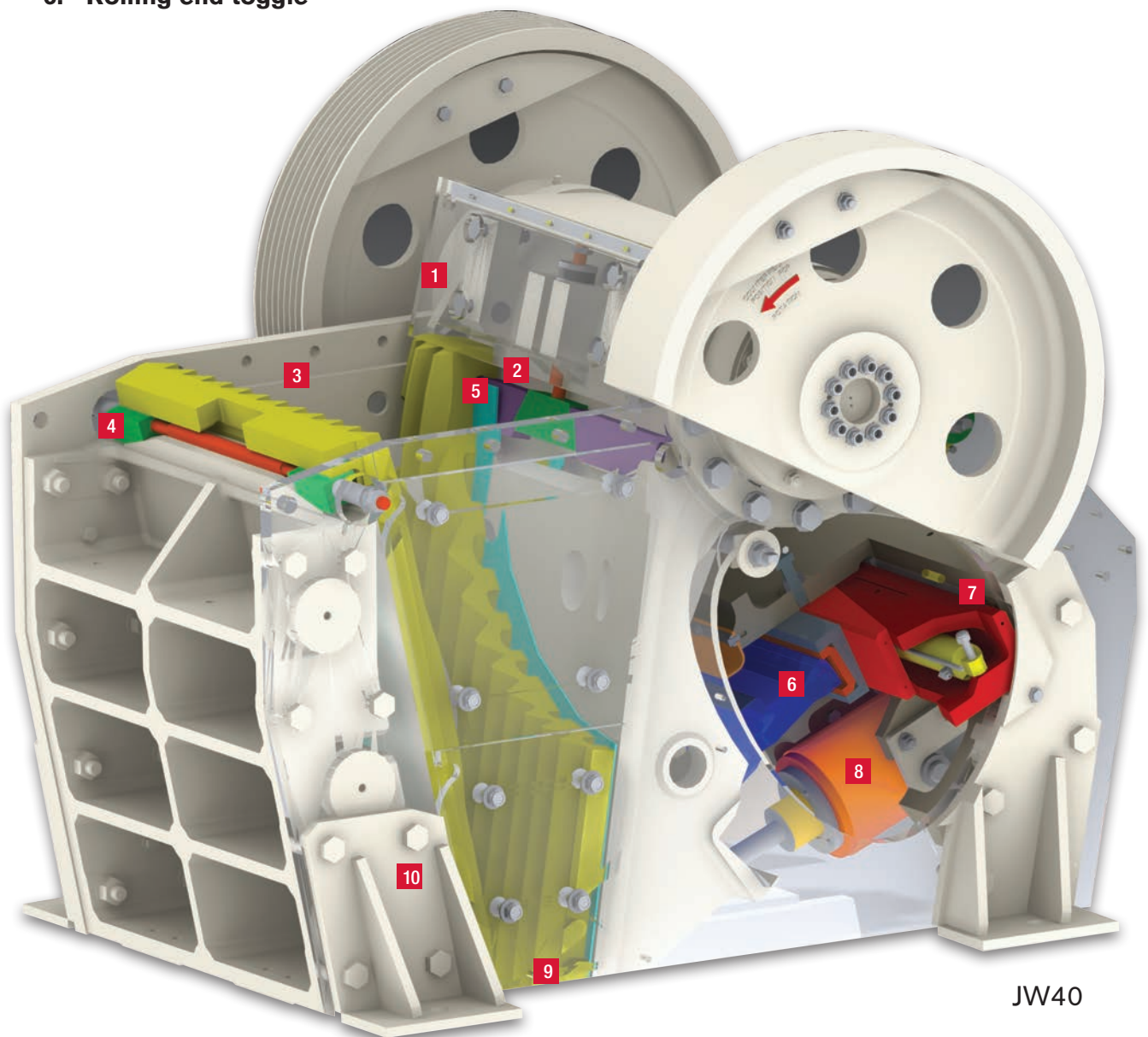

JW40

Durable

► Main frame

The main frame is a heavy-duty design, fully field-tested under arduous conditions.

The frame is a fully bolted and dowelled four-piece structure. Both the front and rear frames are cast high strength steel with the side plates produced from high strength structural plate.

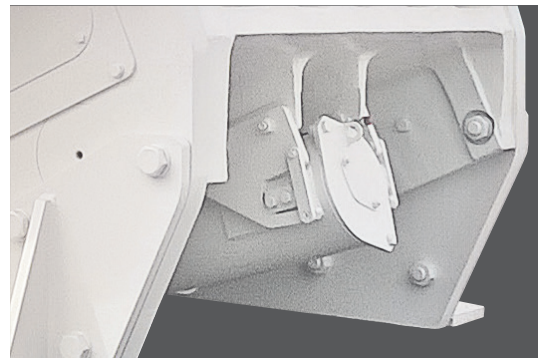
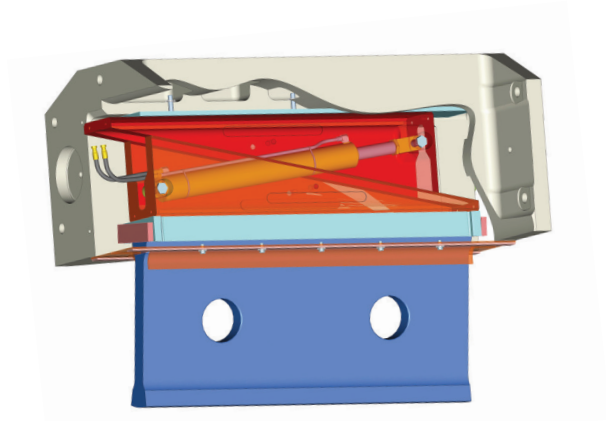
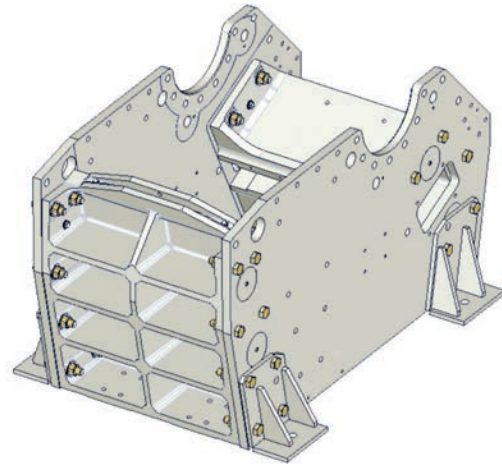

► Closed side setting adjustment

The crusher closed side setting is infinitely adjustable within setting limits through the actuation of hydraulically controlled wedges and tension rod spring. The wedge assembly is fully contained within the crusher frame.

A hydraulic power pack, positioned close to the crusher, provides push button control.

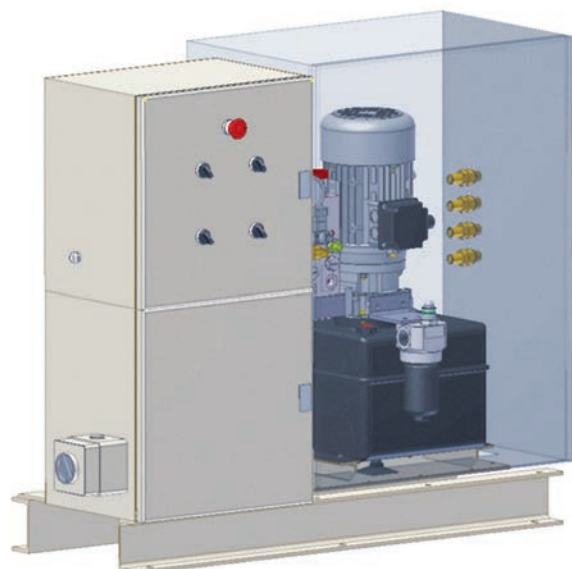

RELIABLE

JW Series Jaw Crusher Construction

▶ Main shaft

The main shaft is of large diameter and is forged from hardened and tempered alloy steel to suit heavy-duty applications. The shaft has high fatigue resistance because of its quality surface finish and the absence of screw threads and sharp radii that can cause stress concentrations.

▶ Bearings

Heavy-duty self-aligning double row roller bearings are used for both the jaw-holder and main frame.

▶ Dust seals

Grease purged labyrinth dust seals.

▶ Jaw-holder

The jaw-holder is a robust, one-piece alloy steel casting for high strength and durability.

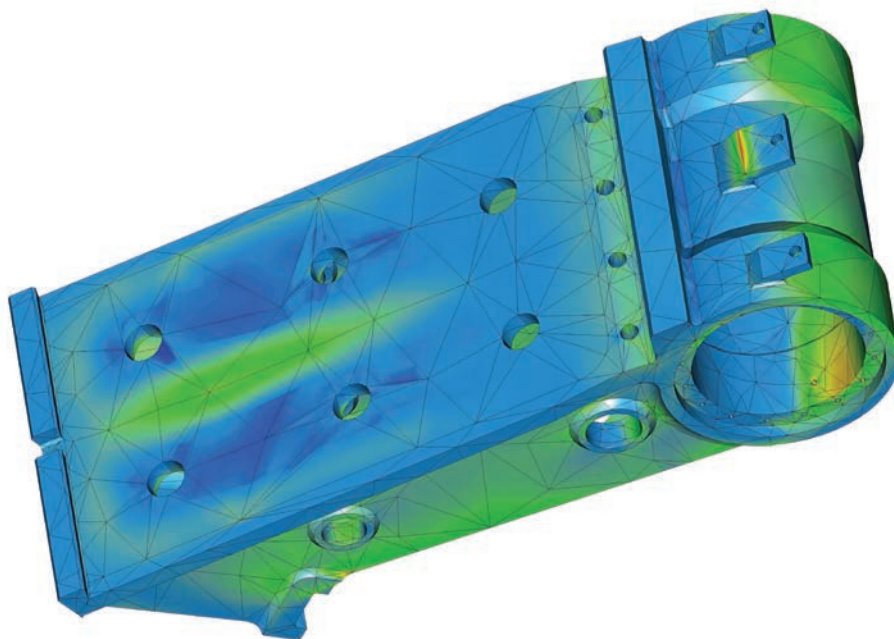
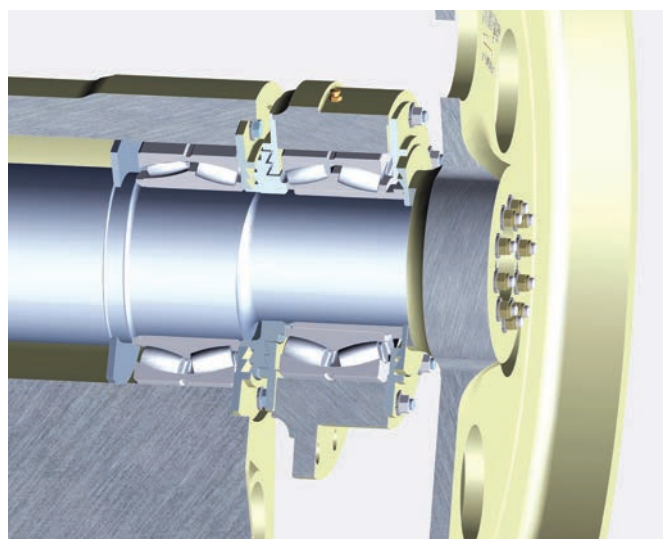

Low Maintenance

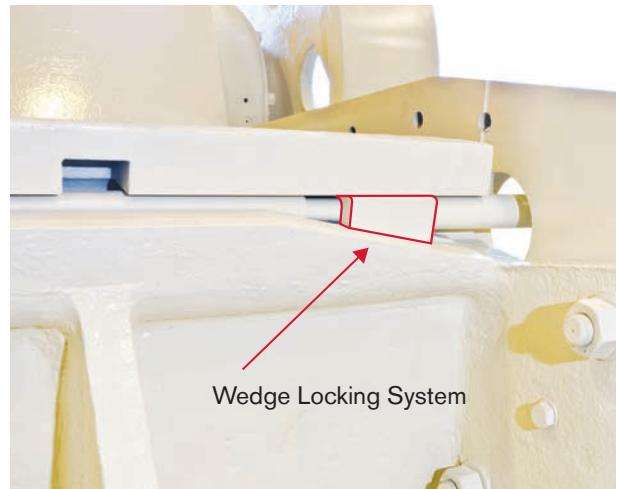
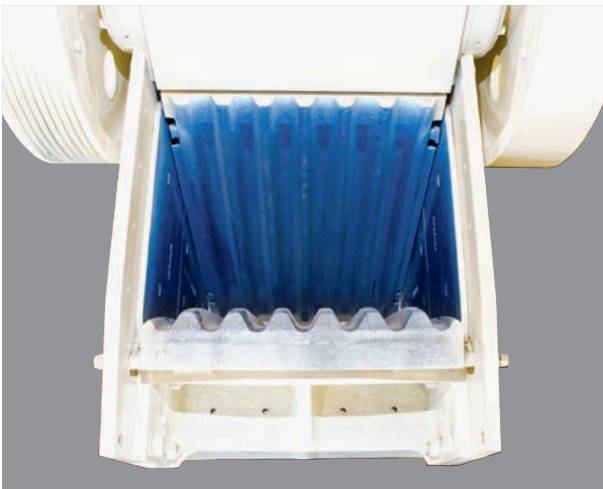

► Jaws

Reversible high quality cast manganese jaws guarantee long service.

The back faces of the jaws are machined for firm support.

The front end frame and swing jaw holder are protected from wear and damage at the inlet and discharge ends, due to the overlapping design of the jaw dies.

Replaceable backing plates protect the jaw die seating areas on the front end frame and swing jaw holder.

At the top of the jaw-holder, a guard protects the bearing housing.

A comprehensive range of jaw-face profiles are matched with the right manganese alloys to maximise crushing performance, jaw life and reduce operating costs.

► Jaw-face retention

The fixed jaw die is retained by a side access wedge locking system, eliminating the need to access jaw wedge retention bolts at the back of the front end frame.

PROVEN

JW Series Jaw Crusher Construction

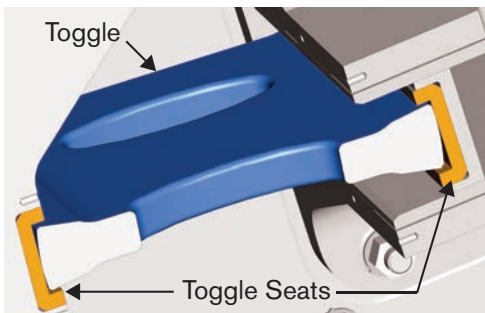

► Toggle

The toggle rolls across the flat pressure face of the toggle seat. There is no rubbing or scuffing and friction is kept to a minimum. This toggle system has the following advantages:

- No lubrication is required
- The system can handle high crushing pressures
- Increased life of the toggle and seats

► Machine robustness and rigidity

Terex® JW Series single toggle jaw crushers have been designed using our long experience in manufacturing machines to handle exceptionally heavy and continuous loads in mining, quarrying, and concrete demolition applications. Heavy-duty self-aligning double-row roller bearings in both the swing jaw and main frame, a heavy-duty alloy forged shaft, cast jaw-holder and a heavy-duty, bolted and dowelled main frame all work together to meet these demands.

► Options available

- Automatic lubrication system for bearing and seals
- Bearing temperature sensors
- Drives
- Flywheel and drive guards
- Modular support base



Why It Matters

Terex® JW Series Jaw Crushers		Why It Matters
✓	Full hydraulic closed side setting adjustment.	Fast, easy, safe adjustment.
✓	Wedge jaw-face locking arrangement.	Easy maintenance access and fast jaw-face change-out.
✓	Tight crushing chamber nip angle.	To aggressively grip rock for increased crusher throughput and jaw life.
✓	Large crushing stroke.	To maximise production.
✓	Adaptable mounting arrangement.	For mobile or static installations.
✓	Extensive distributor network providing spares and service support.	Greatly reduces downtime and lets you plan production confidently.
✓	Process knowledge of technical staff.	Expert help in integrating jaw crushers into your plant.
✓	Proven in the field.	A factor in your Duty of Care in selecting equipment.

ROBUST

JW Series Jaw Crusher Specifications

► Machine specifications

		JW40	JW42	JW55
Feed Opening	mm	660 x 1000	760 x 1070	820 x 1400
	inch	26 x 40	30 x 42	32 x 55
Maximum Power	kW	90	110	150
	hp	120	150	200
Maximum RPM		280	265	250
PCD of Pulley	mm	1190 8SPC	1390 10SPC	1645 10SPC
	inch	46.85	54.7	64.8
Heaviest Lift	kg	5525	8020	9700
	lbs	12175	17670	21370
Total Weight	kg	11830	17740	26250
	lbs	26070	39100	57860
Flywheel Diameter	mm	1200	1400	1650
	inch	47	55	65
Flywheel Face	mm	220	250	275
	inch	9	10	11
Stationary Jaw Length	mm	1385	1665	1775
	inch	55	66	70
Movable Jaw Length	mm	1455	1720	1750
	inch	57	68	69

Dimensions

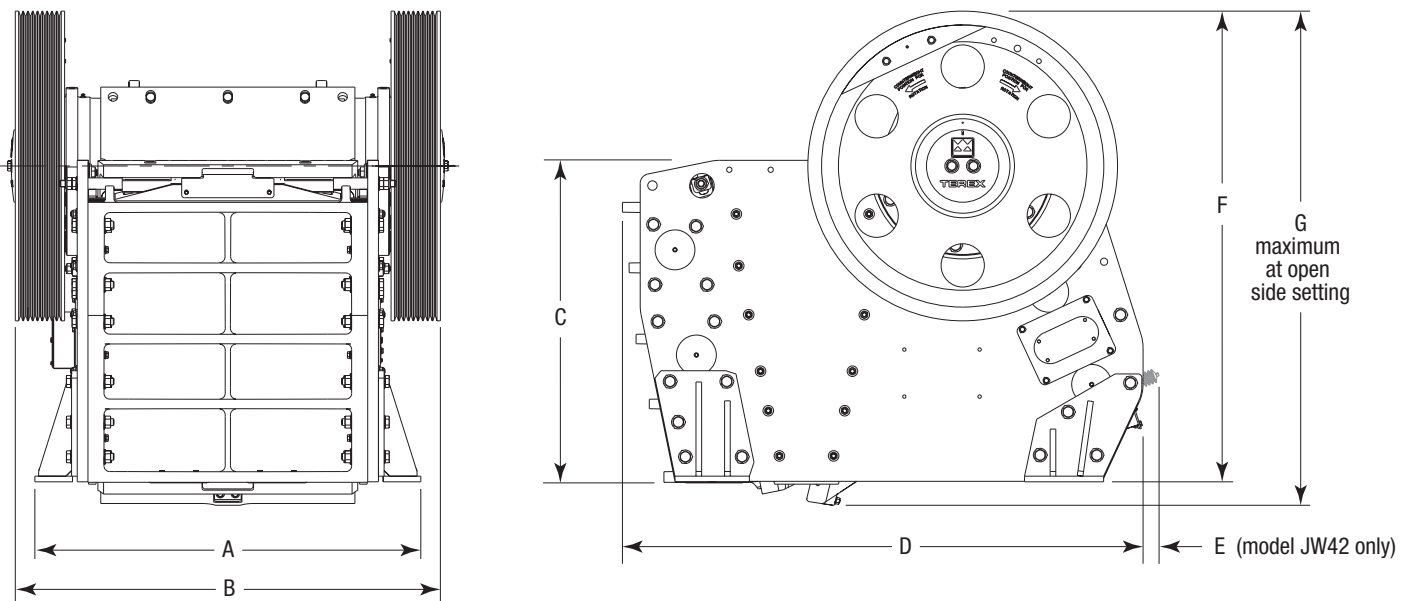

JW Series Jaw Crusher Dimensions			
	Model JW40	Model JW42	Model JW55
A	1598 mm (63")	1656 mm (65")	2050 mm (81")
B	1759 mm (69")	1912 mm (75")	2258 mm (89")
C	1317 mm (52")	1707 mm (67")	1713 mm (68")
D	2295 mm (90")	2546 mm (100")	2765 mm (109")
E	-	83 mm (3.5")	-
F	1916 mm (76")	2412 mm (95")	2500 mm (99")
G	2050 mm (81")	2493 mm (98")	2625 mm (104")

PRODUCTIVE

JW Series Jaw Crusher Capacities

► Machine capacity

The JW Series of single toggle jaw crushers is designed with a tight crushing chamber nip angle and an aggressive crushing stroke to maximise productivity.

The accompanying table gives typical outputs for our range of machines, based on dry, free flowing material with a crushing work index of 16 and a bulk density of 1600 kg/cu m (100 lbs/cu ft).

The table requires careful interpretation for particular materials and applications as machine capacity can be greatly affected by material properties and method of feeding.

Model	Units	Approximate throughput in Metric Tonnes per hour and Short Tonnes per hour (1 metric tonne [Mtp] = 2204 lb and 1 short tonne [Stph] = 2000 lb)												
		Closed Side Setting (mm)												
		mm	50	63	75	88	100	115	125	140	150	165	175	200
inch	2	2.5	3	3.5	4	4.5	5	5.5	6	6.5	7	8	9	
JW40	Mtp	85 - 95	105 - 120	125 - 145	150 - 165	170 - 190	200 - 220	220 - 240	250 - 275	260 - 290	285 - 325			
	Stph	95 - 105	115 - 135	140 - 160	165 - 185	190 - 215	225 - 245	245 - 265	275 - 310	295 - 325	320 - 365			
JW42	Mtp			135 - 160	165 - 185	190 - 210	220 - 240	240 - 265	275 - 305	290 - 320	315 - 355	355 - 380	390 - 430	
	Stph			155 - 175	180 - 205	210 - 235	245 - 270	270 - 295	305 - 340	325 - 360	355 - 400	375 - 425	435 - 480	
JW55	Mtp				230 - 255	265 - 295	310 - 340	340 - 370	380 - 425	405 - 450	440 - 500	470 - 530	545 - 605	610 - 680
	Stph				255 - 290	295 - 330	345 - 380	380 - 410	430 - 475	455 - 500	495 - 560	525 - 595	610 - 675	685 - 760

Closed side setting is measured peak to valley of corrugations.

Product Gradations

▶ Product gradation

The curves shown give an indication of the likely product and are based on material of medium hardness with a crushing work index of 16. Factors that markedly affect results are:

- Structure of material
- Compressive strength or crushing work index of material
- Grading of crusher feed
- Degree of pre-scalping
- Choke versus irregular or low rate of feed

We are pleased to examine specific applications and advise on the likely results from our machines.

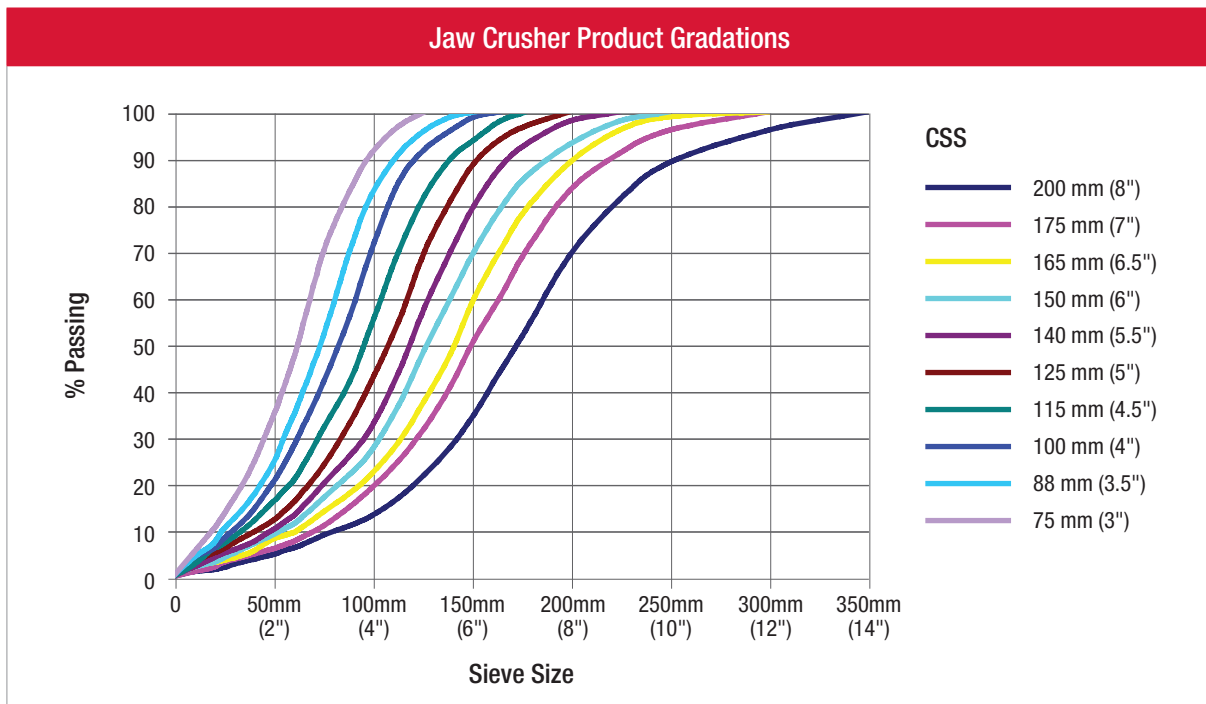

Footnote: These product curves are to be used as a guide only. Crusher product is dependant on feed material properties. Please consult Terex® Minerals Processing Systems for advice on product gradations for specific feed materials.

VERSATILE

JW Series Jaw Crusher Enquiry Details

When enquiring about the range of Terex® JW Series Jaw Crushers please supply the following details so that the jaw crusher best suited may be recommended (email or fax this form to your local Terex® Minerals Processing Systems distributor).

Enquiry Details	
Type of material to be crushed	
Bulk density of feed material	kg/cubic metre (lbs/cubic foot)
Maximum feed lump dimensions	mm x mm x mm (inch x inch x inch)
Characteristics of the material - hard, soft, slabby, moist or wet, sticky, contains clay or other deleterious materials	
Required capacity	metric tonnes/hour (short tons/hour)
Method of feeding, e.g. apron feeder, vibrating grizzly feeder	
Required product size	mm (inch)

JW Series Jaws Work For You

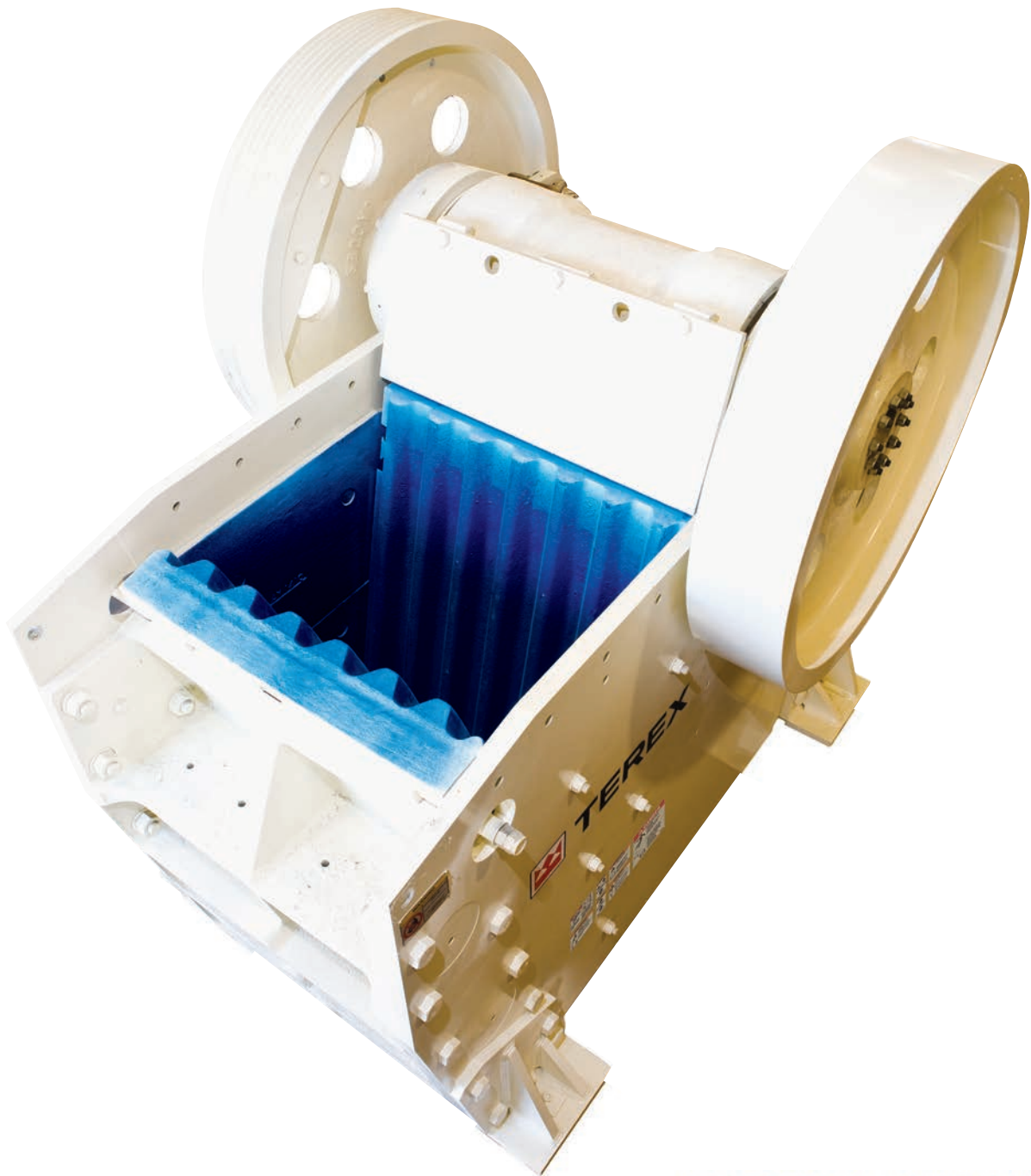

WORKS FOR YOU.™



JW Series Jaw Crushers

- ▶ High production
- ▶ Aggressive crushing action
- ▶ High strength design
- ▶ Full hydraulic setting adjustment
- ▶ Complete range of jaw profiles

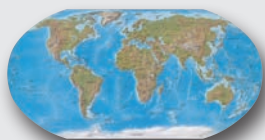

Terex® Minerals Processing Systems

North America

+1 (800) 821-5600

Latin and South America

+1 (319) 363-3511

Europe, Russia and Africa

+44 (0) 28 87 718 777

Turkey, Middle East and North Africa

+90 312 354 90 90

Australia

+61 3 8551 9300

India

+91 4344 302 000

Malaysia

+60 3 5622 6103

Thailand

+66 2 316 4656

Give us a call to learn more about our extensive equipment range.

www.terexmps.com

Effective Date: June 2015. Product specifications and prices are subject to change without notice or obligation. The photographs and/or drawings in this document are for illustrative purposes only. Refer to the appropriate Operator's Manual for instructions on the proper use of this equipment. Failure to follow the appropriate Operator's Manual when using our equipment or failure to act responsibly may result in serious injury or death. The only warranty applicable to our equipment is the standard written warranty applicable to the particular product and sale and Terex makes no other warranty, express or implied. Terex, the Terex Crown design, and Works For You are trademarks of Terex Corporation or its subsidiaries. All rights are reserved. © 2015 Terex Minerals Processing Systems.

Terex® Minerals Processing Systems ▪ Email MPSales@terex.com ▪ www.terexmps.com
Form 25551 A4 (6/15)



WORKS FOR YOU.™